

LEGEND:

LPS	LOW PRESSURE SWITCH
HPS	HIGH PRESSURE SWITCH
SC	SOLENOID
BKR1	15A BREAKER
TB1	TERMINAL BLOCK
P1	POWER HARNESS
P2	CLUTCH CABLE ASSEMBLY
R1	DPDT POWER RELAY 24VDC
FAN1,FAN2	CONDENSER FAN
COMPRESSOR	24VDC COMPRESSOR

BILL OF MATERIALS

PART NUMBER	QTY	DESCRIPTION
MN60-10-001	1	LOW PRESSURE SWITCH
MN60-10-002	1	HIGH PRESSURE SWITCH
NPMN40-01-000	1	SOLENOIDE, CONTINUOUS DUTY 24C, 85A
NPMN40-02-021	1	15A BREAKER (24VDC)
NPMN40-04-059	1	TERMINAL BLOCK
NPMN40-17-029	1	MAIN POWER HARNESS
NPMN40-17-043	1	CLUTCH CABLE ASSEMBLY
RMN04-01-003	1	DPDT POWER RELAY 24VDC
RMN58-01-092	2	HC RC CONDENSER FAN
RMN58-01-093	1	HC RC COMPRESSOR

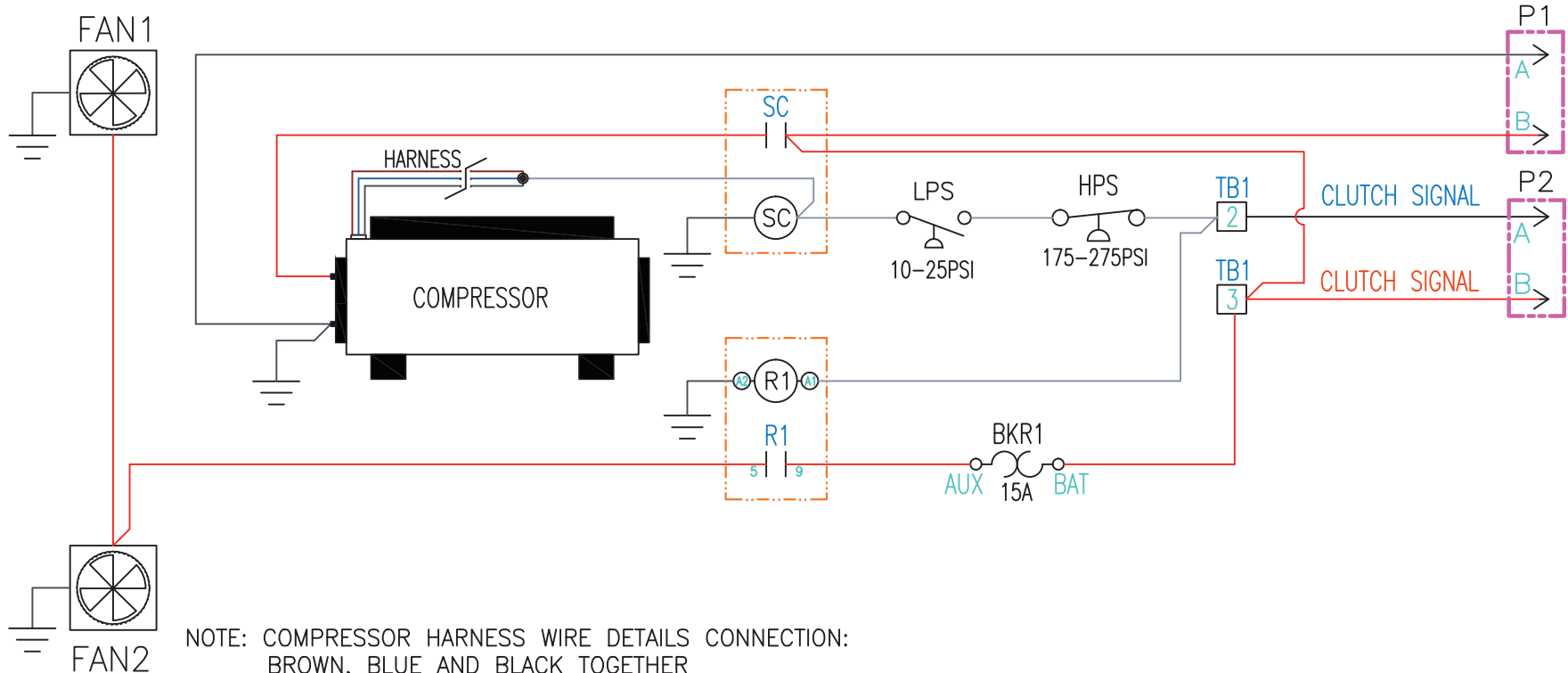

NOTE: COMPRESSOR HARNESS WIRE DETAILS CONNECTION:
BROWN, BLUE AND BLACK TOGETHER
ORANGE NOT USE.

	TITLE HC REMOTE CONDENSER UNIT WIRING DIAGRAM	
	SHEET 1 OF 1	PRODUCT HC REMOTE COND. UNIT
DRAWN BY NH	DATE 07-09-2015	DRAWING NO. ES-RMNHCR-CWC-01
CHECKED NO SCALE	SCALE NO SCALE	SIZE A
		REV. 1.0